

Han® K 3/0, K 3/2 / Han® HC Modular	Page
Technical characteristics Han® K 3/0, Han® K 3/2	14.10
Inserts Han® K 3/0, Han® K 3/2	14.11
Han® 24 HPR special hoods/housings for Han® K 3/0, Han® K 3/2	14.12
Technical characteristics Han® HC Modular 350	14.14
Contacts Han® HC Modular 350	14.15
Hoods/housings for working voltage: 2 000 V Han® HC Modular	14.16
Hoods/housings for working voltage: 4 000 V Han® HC Modular	14.17
Assembly details for Han® HC Modular 350	14.19
Technical characteristics Han® HC Modular 650	14.20
Contacts Han® HC Modular 650	14.21
Hoods/housings for Han® HC Modular 650	14.21
Assembly details for Han® HC Modular 650	14.22
Han® 48 HPR	14.23

Specifications

DIN VDE 0627
DIN VDE 0110
DIN EN 61984

Inserts

Number of contacts 3, 3/2 + PE

Electrical data
acc. to DIN EN 61984

Power area **200 A 1150/2000 V 8 kV 3**

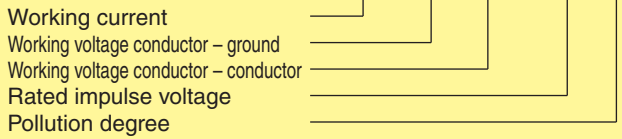

- Pollution degree 2 also 200 A 2000 V 12 kV 2

Signal area **16 A 400 V 6 kV 3**

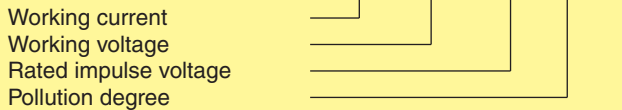

- Pollution degree 2 also 16 A 500 V 6 kV 2

Insulation resistance $\geq 10^{10} \Omega$
Material Polycarbonate
Limiting temperatures $-40^{\circ}\text{C} / +125^{\circ}\text{C}$
Flammability acc. to UL 94 V 0
Mechanical working life
- Mating cycles ≥ 500

Current carrying capacity acc. to IEC 512

The current carrying capacity is limited by maximum temperature of materials for inserts and contacts including terminals. The current capacity-curve is valid for continuous, not interrupted current-loaded contacts of connectors when simultaneous power on all contacts is given, without exceeding the maximum temperature.

Control and test procedures according to DIN IEC 512-3.

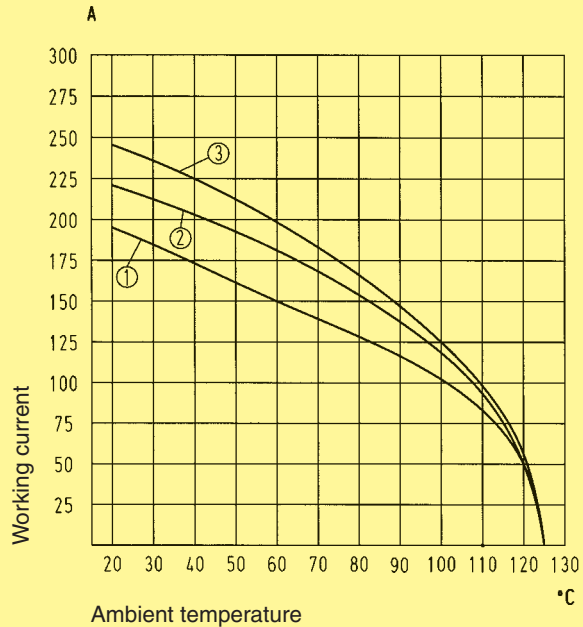

- ① Wire gauge: 35 mm²
- ② Wire gauge: 50 mm²
- ③ Wire gauge: 70 mm²

Features

- Only to be used with Han® 24 HPR special hoods and housings (see page 14.12)
- Only available with axial screw termination
- The vertical and angled versions offer solutions for almost all applications
- The ideal connector for transmission of high currents requiring little space

Han® HPR hoods/housings

Technical characteristics

Material	corrosion resistant aluminium alloy
Surface	
- top coat	Epoxy powder paint
Locking elements	V2A
Kind of locking	Screw
Seal	NBR
Limiting temperatures	$-40^{\circ}\text{C} / +125^{\circ}\text{C}$
Degree of protection acc. to DIN EN 60529 for coupled connector	IP 68

Features

- Epoxy powder paint finish
- EMC protection
- Corrosion resistant
- Pressure tight

Contacts

Material copper alloy
Surface silver
Contact resistance $\leq 0.2 \text{ m}\Omega$

Axial screw contact
- Wire gauge
- Tightening torque

mm ²	35	50	70
Nm	8	9	10

Power contact
- Wire gauge¹⁾ 35 - 70 mm²
- AWG 2 - 2/0
- Tightening torque 8 - 10 Nm
- Hexagonal wrench SW 5, 09 99 000 0371, page 99.05
- Stripping length 22 mm

PE contact (only Han K 3/2)¹⁾
- Wire gauge 16 - 35 mm²
- AWG 5 - 2
- Tightening torque 6 Nm
- Hexagonal wrench SW 4, 09 99 000 0370, page 99.05
- Stripping length 14 mm

Signal contact (only Han K 3/2)
- Wire gauge 2,5 mm²
- AWG 14
- Tightening torque 0.5 Nm
- Stripping length 7 mm

¹⁾ geometrical diameter

Number of contacts



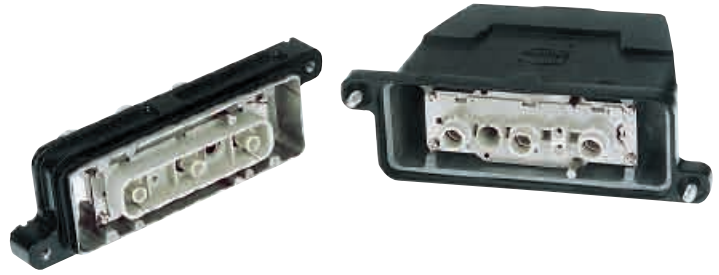





3/0 without 
 3/2 with 

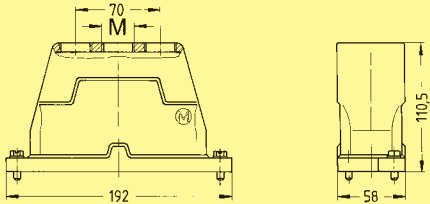
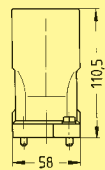

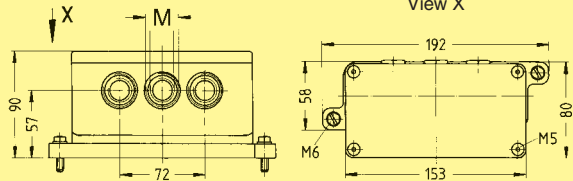
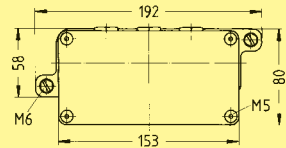
Inserts

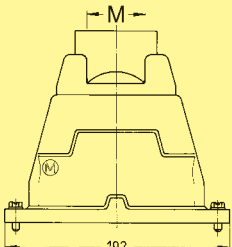
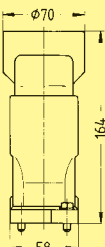
Identification	Serie	Part No.		Drawing	Dimensions in mm
		Male insert (M)	Female insert (F)		
Axial screw terminal top-entry angled	Han® K 3/0	09 38 005 2621	09 38 005 2721		
		09 38 005 2622	09 38 005 2722		
	Han® K 3/2	09 38 005 2601	09 38 005 2701		
		09 38 005 2602	09 38 005 2702		
		1) Distance for contact max. 21 mm			
		1) Distance for contact max. 21 mm			

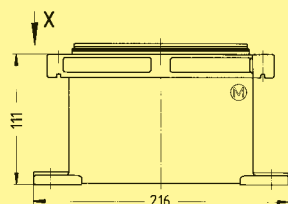
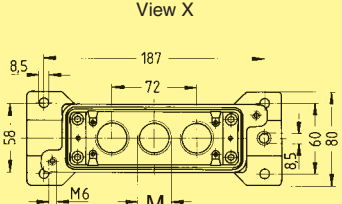
Han HC Modular

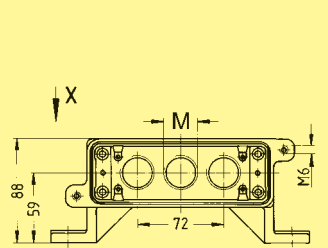
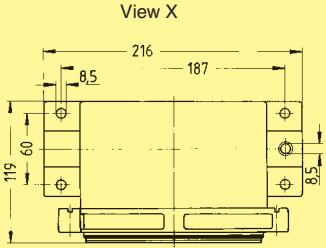
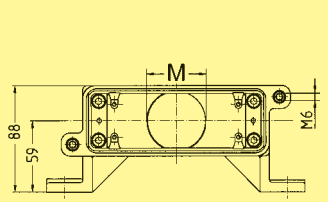
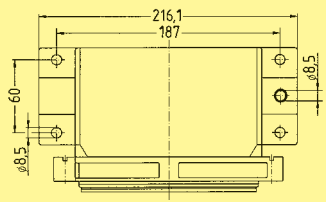
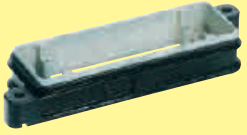
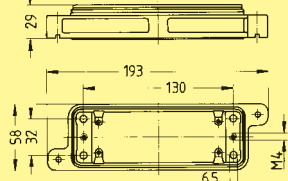
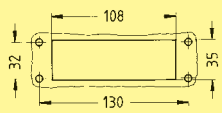
Identification	Part No. Screw locking	Serie M	Drawing	Dimensions in mm
Hood top-entry 	19 40 024 0461	Han® K 3/0 3 x 25		
angled entry 	19 40 024 0631	3 x 25		
top-entry for M 63 	19 40 024 0420	Han® K 3/2 63		
Housing surface mounting straight version 	19 40 024 1231	Han® K 3/0 3 x 25		
horizontal version 	19 40 024 0931	3 x 25		
	19 40 024 0914	50		
Housing bulkhead mounting 	09 40 024 0311	Han® K 3/0 + 3/2 24		Panel cut out: 108 x 35 mm 

Han HC
Modular

Regional Express Railcars
of the series ET 424-426
Bombardier Transportation,
Siemens AG, ALSTOM

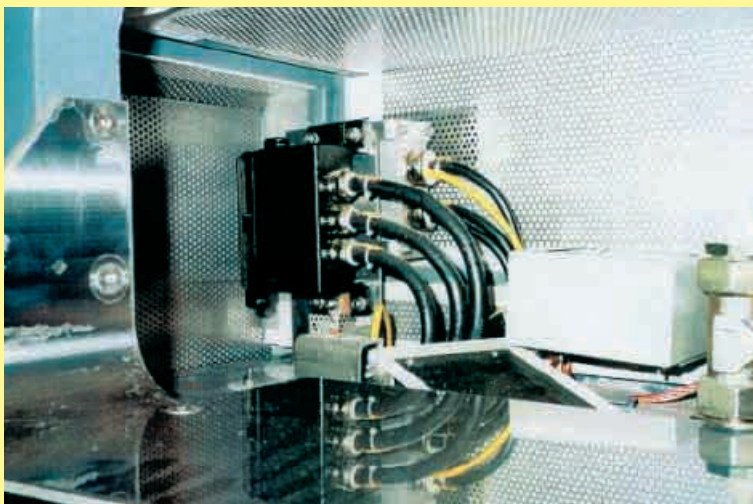

Motor connection of the traction bogie
with Han® K 3/0 and Han® HPR hood/
housing
Bombardier Transportation,
Siemens AG, ALSTOM

Han HC
Modular



Modular High Current Connector System

Technical characteristics

Specification	DIN VDE 0627 DIN VDE 0110 DIN EN 61984												
Inserts													
Number of contacts	1, 2, 3 or 3 + PE												
Electrical data acc. to DIN EN 61984													
without adapter	350 A 2000 V 12 kV 3												
Working current													
Working voltage													
Rated impulse voltage													
Pollution degree													
with adapter	350 A 4000 V 18 kV 3												
Working current													
Working voltage													
Rated impulse voltage													
Pollution degree													
Insulation resistance	≥ 10 ¹⁰ Ω												
Material	Polyamide												
Limiting temperatures	- 40 °C / +125 °C												
Flammability acc. to UL 94	V 0												
Mechanical working life													
- Mating cycles	≥ 500												
Contacts													
Material	copper alloy												
Surface	silver												
Contact resistance	≤ 0.2 mΩ												
Axial screw terminal													
- Wire gauge ¹⁾	35 - 70 mm ² or 95 - 120 mm ²												
- AWG	1 - 00												
- Hexagonal wrench	000 - 0000												
- Tightening torque	SW 5, 09 99 000 0371, page 99.05												
	<table border="1"> <tr> <td>mm²</td> <td>35</td> <td>50</td> <td>70</td> <td>95</td> <td>120</td> </tr> <tr> <td>Nm</td> <td>8</td> <td>10</td> <td>12</td> <td>14</td> <td>16</td> </tr> </table>	mm ²	35	50	70	95	120	Nm	8	10	12	14	16
mm ²	35	50	70	95	120								
Nm	8	10	12	14	16								
Stripping length	19 ⁺¹ mm												
Max. cable diameter	19.5 mm												
Screw terminal													
- Thread	M 10												
- Hexagonal wrench	SW 17												
- Tightening torque	14 Nm												
Frame													
Tightening torque of the fixing screws	0.5 Nm												
Tightening torque of the cross-tying screws on the frame for 4 poles	1.5 Nm												

Current carrying capacity acc. to IEC 512

The current carrying capacity is limited by maximum temperature of materials for inserts and contacts including terminals. The current capacity-curve is valid for continuous, not interrupted current-loaded contacts of connectors when simultaneous power on all contacts is given, without exceeding the maximum temperature.

Control and test procedures according to DIN IEC 512-3.

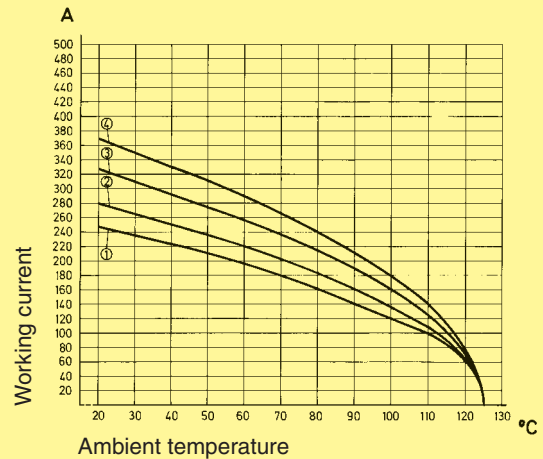

- ① Wire gauge: 50 mm²
- ② Wire gauge: 70 mm²
- ③ Wire gauge: 95 mm²
- ④ Wire gauge: 120 mm²

three contacts in HPR size 24







Han® HPR Hoods/Housings

Material	corrosion resistant aluminium die-cast
Surface	
- Top coat	powder paint RAL 9005
Locking elements	V2A steel
Kind of locking	screw
Seal	NBR
Limiting temperatures	- 40 °C / +125 °C
Degree of protection acc. to DIN 40 050 for coupled connector	IP 68

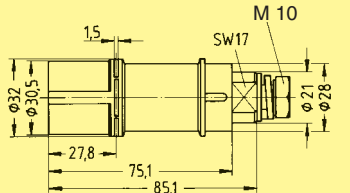
Han® M Hoods/Housings

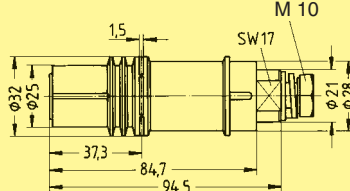
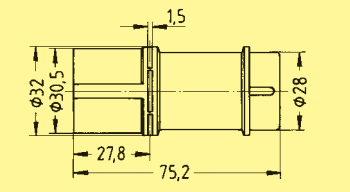
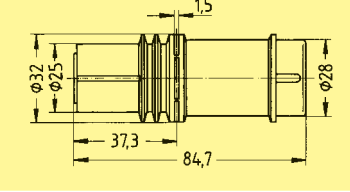
Material	corrosion resistant aluminium die-cast
Surface	
- Top coat	powder paint RAL 9005
Locking elements	V2A steel
Seal	FPM
Limiting temperatures	- 40 °C / +125 °C
Degree of protection acc. to DIN 40 050 for coupled connector	IP 65

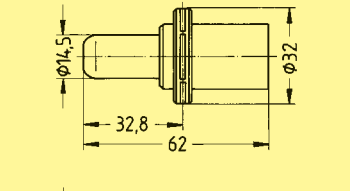
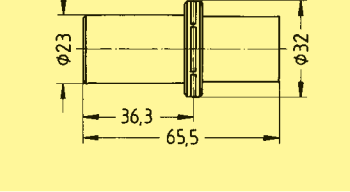
¹⁾ geometrical diameter

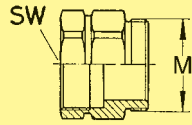
Contacts	Part No.		Wire gauge	Drawing	Dimensions in mm
	Male contact (M)	Female contact (F)			
Straight version with screw terminal only for housing bulkhead mounting 	09 11 001 2655	09 11 001 2755	for cable lug up to max. 120 mm ²		
with axial screw terminal 	09 11 001 2651 09 11 001 2652	09 11 001 2751 09 11 001 2752	35 - 70 mm ² 95 - 120 mm ²	  	
PE contact with axial screw terminal 	09 11 000 6156	09 11 000 6256	35 - 70 mm ²	 	
Hexagonal wrench adapter (SW 5) 	09 99 000 0371				
Hexagonal adapter	Part No.	M	SW	Drawing	Dimensions in mm
Metal version with O-Ring 	19 36 000 5134 19 36 000 5135	25 32	30 40		

Han HC
Modular

Han HC Modular

Frame	Part No.	Hoods/Housings top-entry	M	Part No.								
<p>1 pole for hood</p>	09 11 000 9951	<p>Hood Han® HPR 6 B</p>	25 32	19 40 006 0411 19 40 006 0412								
<p>1 pole for housing</p>	09 11 000 9951	<p>Housing bulkhead mounting Han® HPR 6 B</p> <table border="1"> <thead> <tr> <th>Size</th> <th>a</th> <th>b</th> <th>c</th> </tr> </thead> <tbody> <tr> <td>6 B</td> <td>70</td> <td>133</td> <td>48</td> </tr> </tbody> </table>	Size	a	b	c	6 B	70	133	48	—	09 40 006 0311
Size	a	b	c									
6 B	70	133	48									
<p>3 poles with PE for hood</p>	09 11 000 9954	<p>Hood Han® 48 M</p>	4 x 25	19 37 048 0401								
<p>3 poles with PE for housing</p>	09 11 000 9955	<p>Housing bulkhead mounting Han® 48 M</p>	—	09 37 048 0301								

Frame	Part No.	Hoods/Housings top-entry	M	Part No.								
<p>3 poles</p> <p>enclosed separately</p>	09 11 000 9963	<p>Hood Han® HPR 24 B</p>	3 x 25	19 40 024 0461								
<p>3 poles</p> <p>enclosed separately</p>	09 11 000 9963	<p>Hood Han® HPR 24 B</p>	3 x 32	19 40 024 0467								
<p>3 poles</p> <p>enclosed separately</p>	09 11 000 9963	<p>Housing bulkhead mounting Han® HPR 24 B</p> <table border="1"> <thead> <tr> <th>Size</th> <th>a</th> <th>b</th> <th>c</th> </tr> </thead> <tbody> <tr> <td>24 B</td> <td>130</td> <td>193</td> <td>108</td> </tr> </tbody> </table>	Size	a	b	c	24 B	130	193	108	—	09 40 024 0311
Size	a	b	c									
24 B	130	193	108									
<p>3 poles</p> <p>enclosed separately</p>	09 11 000 9963	<p>Housing surface mounting Han® HPR 24 B horizontal version</p>	3 x 25	19 40 024 0931								
<p>3 poles</p> <p>enclosed separately</p>	09 11 000 9963	<p>Housing surface mounting Han® HPR 24 B straight version</p>	3 x 25	19 40 024 1231								

Han HC Modular

* A working voltage of 4 000 V is only possible to realize by using a hexagonal adapter and the HARTING cable gland, in order to realize the clearance and creepage distances according to DIN VDE 0110.

Stock items in bold type

Assembly Details

Remarks on the Axialscrew termination see page 00.15

Step 1: The outer diameter of the cable must not exceed 19.5 mm. Strip the cable by 19 mm.

Insert the cable through hood.

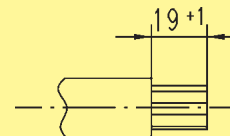

Step 2: Press the Han HC contact C on the cable strand and apply tightening torque according to table 1 by using a tightening torque tool. Take care that all cable strands fit completely inside the contact termination cavity. During assembling adhere the cable and the contact to minimise axial movement or twisting.

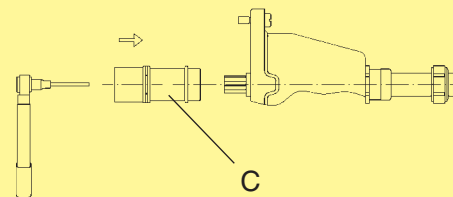

Step 3: Move the perforated plate D across the HC contacts.

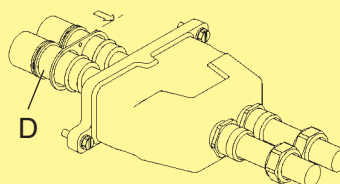

Step 4: Fit frame E onto the hexagon shape of the HC contact. Coding can be arranged by turning the contact within 60° steps. Bolt the frame E together with perforated plate D.

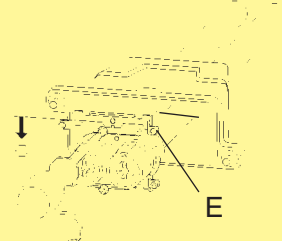

Step 5: Push back the packet inside the hood.

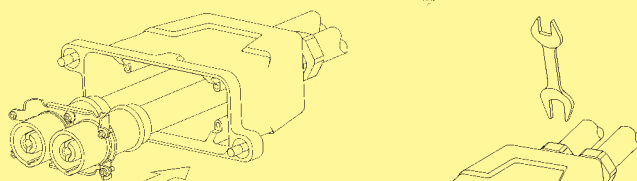

Step 6: Tighten the four M3 screws and the cable gland according to manufacturer recommendation.

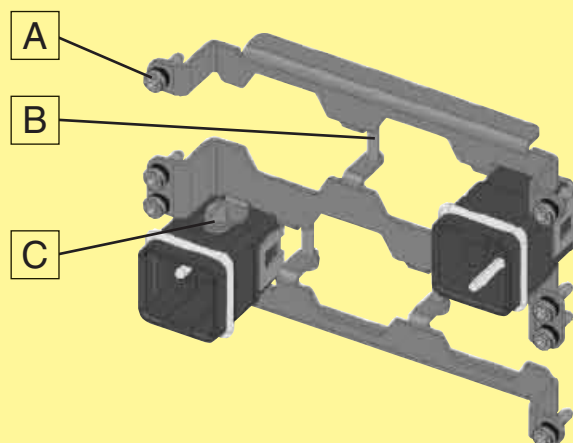
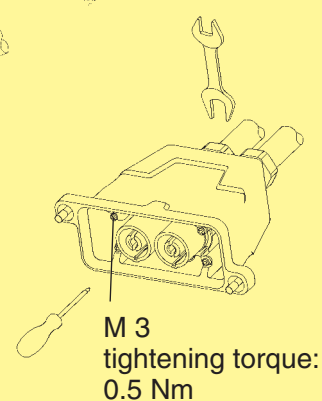

During the assembly of the frame for 4 poles the following tightening torques have to be taken into consideration:

- A = 0.5 Nm
- B = 1.5 Nm
- C = 0.25 Nm



Modular High Current Connector System

Technical characteristics

Specifications	DIN VDE 0627 DIN VDE 0110 DIN EN 61 984
----------------	---

Contacts	
Material	copper alloy
Surface	silver
Contact resistance	≤ 0.2 mΩ
Axial screw contact	
- Wire gauge ¹⁾	70 - 120 mm ² or 150 - 185 mm ²
- MCM	138 - 236 or 300 - 350

Inserts	
Number of contacts	1, 2
Electrical data acc. to DIN EN 61 984	650 A 4000 V 18 kV 3
Working current	
Working voltage	
Rated impulse voltage	
Pollution degree	
Insulation resistance	≥ 10 ¹⁰ Ω
Material	Polyamide
Limiting temperatures	- 40 °C / +125 °C
Flammability acc. to UL 94	V 0
Mechanical working life	
- Mating cycles	≥ 500

Stripping length	
------------------	--

Axial screw contact													
- Wire gauge													
- Tightening torque													
	<table border="1"> <tr> <td>mm²</td> <td>70</td> <td>95</td> <td>120</td> <td>150</td> <td>185</td> </tr> <tr> <td>Nm</td> <td>12</td> <td>14</td> <td>16</td> <td>17</td> <td>18</td> </tr> </table>	mm ²	70	95	120	150	185	Nm	12	14	16	17	18
mm ²	70	95	120	150	185								
Nm	12	14	16	17	18								
	min. length of wrench: 60 mm												

Hexagonal wrench Adapter (SW8)	09 99 000 0372 page 99.05
--------------------------------	------------------------------

Screw contact	
- Thread M 12	
- 16 - 18 Nm	
Please ensure to hold up the contact with a wrench size 24 to apply the tightening torque	

Frame	
Material	V2A
Tightening torque of the locking screws	0.5 Nm

Han® HPR hoods/housings	
Material	Corrosion resistant aluminium die-cast
Surface	
- top coat	Epoxy powder paint RAL 9005
Locking elements	V2A
Kind of locking	screw
Sealing	NBR
Limiting temperatures	- 40 °C / +125 °C
Degree of protection acc. to DIN 40 050 for coupled connector	IP 68

Current carrying capacity acc. to IEC 512

The current carrying capacity is limited by maximum temperature of materials for inserts and contacts including terminals. The current capacity-curve is valid for continuous, not interrupted current-loaded contacts of connectors when simultaneous power on all contacts is given, without exceeding the maximum temperature.

Control and test procedures according to DIN IEC 512-3.

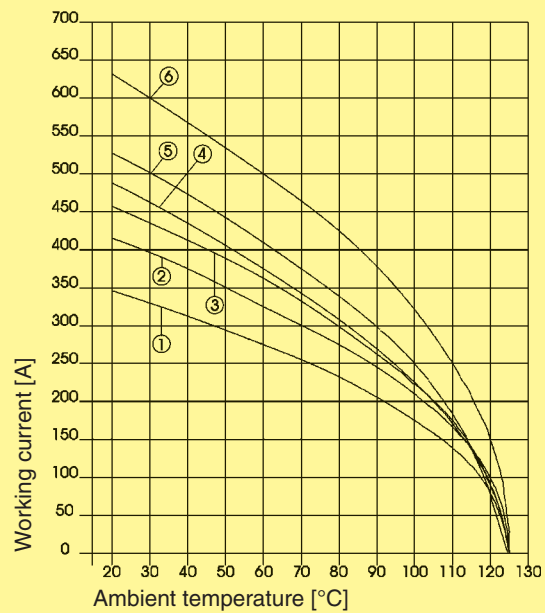

- ① Wire gauge: 70 mm²
 - ② Wire gauge: 95 mm²
 - ③ Wire gauge: 120 mm²
 - ④ Wire gauge: 150 mm²
 - ⑤ Wire gauge: 180 mm²
 - ⑥ Wire gauge: 240 mm²
- with cable SHXAFO1x240, 4 kV

¹⁾ geometrical diameter

Contacts	Part No.		Wire gauge	Male contact	Female contact
	Male contact (M)	Female contact (F)			
Straight version					
	with screw terminal*	09 11 001 2675	09 11 001 2775	70 - 240 mm ²	
with axial screw terminal					
		09 11 001 2671 09 11 001 2672	09 11 001 2771 09 11 001 2772	70 - 120 mm ² 150 - 185 mm ²	

Frame	Part No.	Hoods/Housings top-entry	M	Part No.
<p>1 pole for hood</p> <p>M3x10</p> <p>44, 27, 34, 17, 55</p>	09 11 000 9971	<p>Hood Han® HPR 6 B</p> <p>M6x1.5</p> <p>132, 101, 58, 30</p>	40	19 40 006 0418
<p>1 pole for housing</p> <p>M3x10</p> <p>44, 27, 34, 17, 55</p>	09 11 000 9971	<p>Housing bulkhead mounting Han® HPR 6 B</p> <p>29, 133, 70, 58, 3.7, 6.5</p> <p>Mounting frames from page 30.31 are not fitting for compatibility.</p>	-	09 40 006 0314
<p>2 poles for hood</p> <p>M3x10</p> <p>104, 85.2, 56, 92, 11, 10.1, 27, 44, 17, 24.5</p>	09 11 000 9972	<p>Hood Han® HPR 24 B</p> <p>56, 192, 110, 58, 30</p>	40	19 40 024 0438
<p>2 poles for housing</p> <p>M3x10</p> <p>104, 85.2, 56, 92, 11, 10.1, 27, 44, 17, 24.5</p>	09 11 000 9972	<p>Housing bulkhead mounting Han® HPR 24 B</p> <p>29, 193, 130, 58, 3.7, 6.5</p> <p>Mounting frames from page 30.31 are not fitting for compatibility.</p>	-	09 40 024 0311

Han HC Modular

* only for bulkhead mounting housings

Assembly details

1. Stripping length

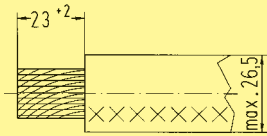

2. + 3.

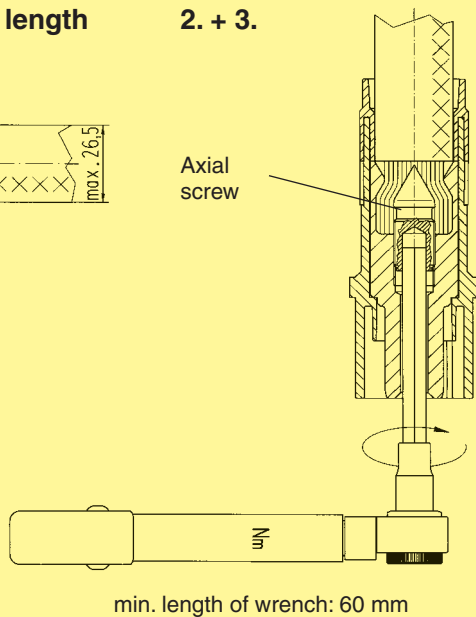

1. Strip cable to 23 ± 2 mm.

2. Push conductor through the cable gland and the housing. Push the stripped end of the conductor into the termination entry of the module until the insulation touches the contact.

3. To tighten the axial screw, a hexagonal wrench size 8 is needed. Insert the hexagonal wrench on the mating side of the contact. At the same time, push the conductor over the axial screw. The locking screw has to be tightened with the recommended tightening torque that is determined by the conductor's cross section.

4. + 5.

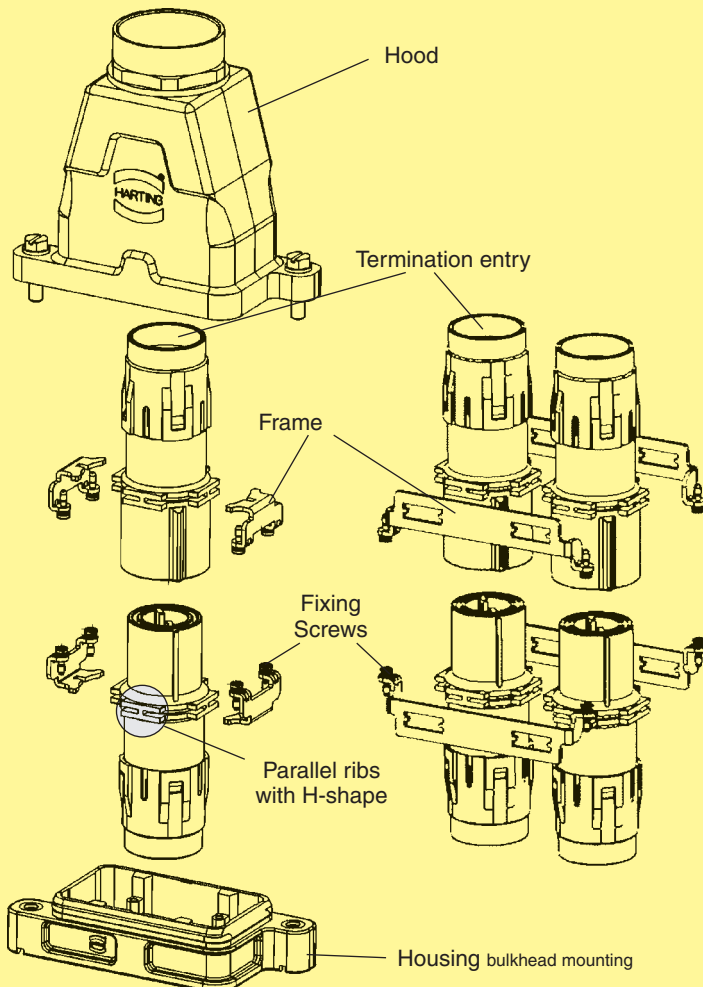

4. Once the modules are terminated, they are mounted into the housing by using two metal frames (tightening torque of the fixing screws = 0.5 Nm). The modules have 4 pegs formed by 2 parallel ribs (each peg shapes like a "H"). Each rib takes 1 pole frame, where the lateral link has to go into the relief of the frame.

The 2 pole frames have 2 cutouts on the wall which get fitted to the "H"-shaped pegs (see figure).

The heads of the screws have to face the mating direction of the module. Coding can be established by rotating the contact by 90 degrees. Therefore it is important that the corresponding modules are assembled in the correct position otherwise mating is not possible.

5. After assembling the modules in the housing, the tightening torque of the locking screw can be checked and corrected if necessary.

6. After final assembly of the contacts, the user should ensure that the cable is adequately strain relieved to protect the contact from radial stress.



Technical characteristics

Inserts

Number of contacts i. e. 4, 5, 6, 10 depending on the frame

Electrical data acc. to DIN EN 61 984

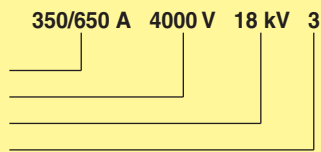

Working current
Working voltage
Rated impulse voltage
Pollution degree

Insulation resistance $\geq 10^{10} \Omega$
Material Polyamide
Contact resistance $\leq 0,2 \text{ m}\Omega$
Limiting temperatures $-40^{\circ}\text{C} / +125^{\circ}\text{C}$
Flammability acc. to UL 94 V 0
Mechanical working life
- Mating cycles ≥ 500

Contacts HC 350

Material copper alloy
Surface silver
Contact resistance $\leq 0.2 \text{ m}\Omega$
Axial screw termination
- Wire gauge¹⁾ 35 - 70 mm² or 95 - 120 mm²
- AWG 1 - 00 or 000 - 0000

Stripping length

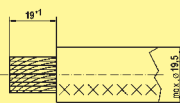

- Wire gauge
- Tightening torque

mm ²	35	50	70	95	120
Nm	8	10	12	14	16

Contacts HC Modular 650

Material copper alloy
Surface silver
Contact resistance $\leq 0.2 \text{ m}\Omega$
Axial screw termination
- Wire gauge¹⁾ 70 - 120 mm² or 150 - 185 mm²
- MCM 138 - 236 or 300 - 350

Stripping length

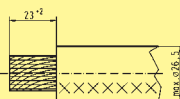

- Wire gauge
- Tightening torque

mm ²	70	95	120	150	185
Nm	12	14	16	17	18

Features

- Well proven Han® HPR design
- Corrosion resistant alloy
- Good EMC features
- Degree of protection IP 68
- Easy assembly
- Secure termination, easy to control
- Vibration resistant acc. to DIN EN 61 373
- Ideal motor / drive connector for the transportation sector







Frame



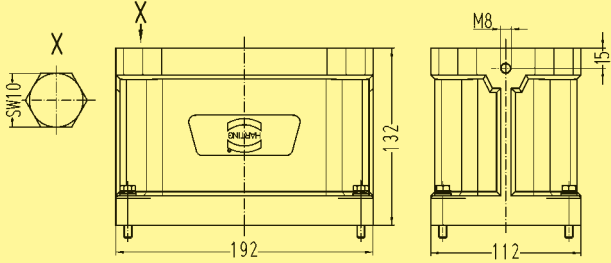

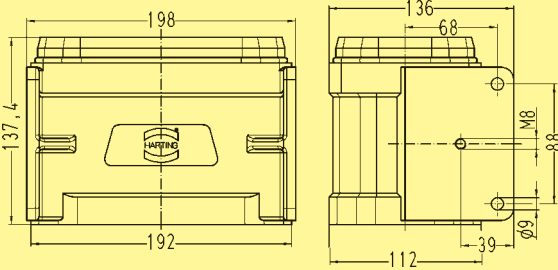

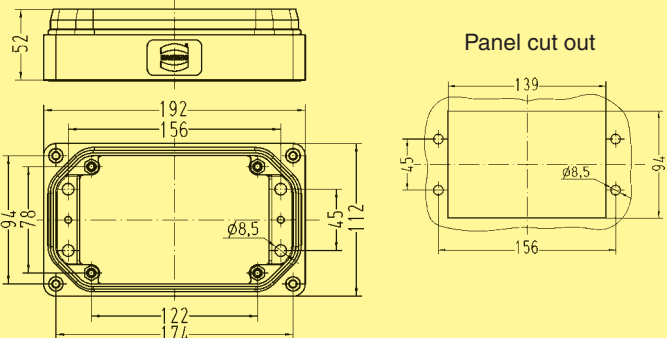

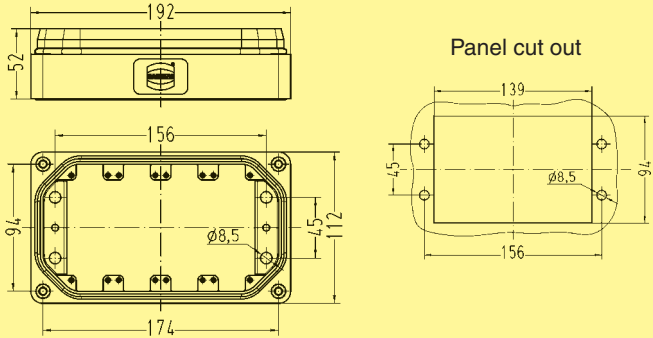

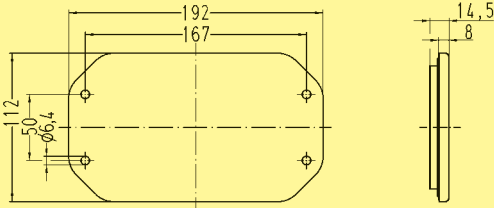
Material V2A
Tightening torque of the locking screws 2 Nm

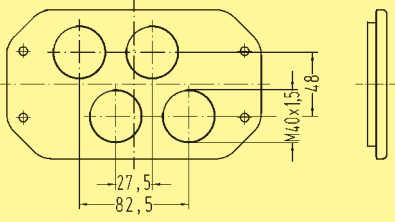
Han® HPR hoods/housings

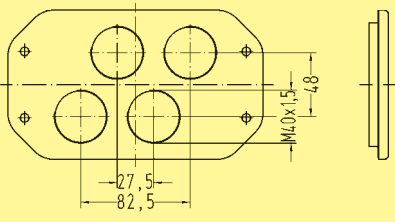
Material Corrosion resistant aluminium die-cast
Surface Epoxy powder paint RAL 9005
Locking elements V2A
Tightening torque 4 Nm
Sealing NBR
Limiting temperatures $-40^{\circ}\text{C} / +125^{\circ}\text{C}$
Degree of protection acc. to DIN 60 529 for coupled connector IP 68

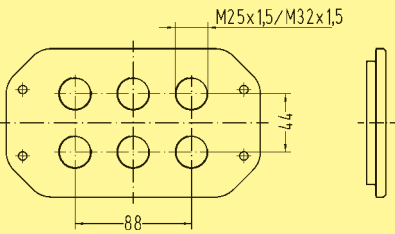
¹⁾ geometrical diameter

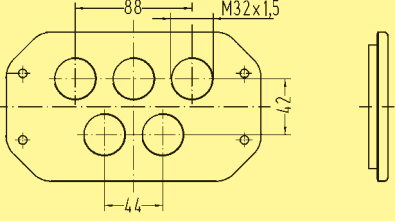
Identification	Part No.	Drawing	Dimensions in mm
<p>Hood</p> 	<p>09 40 048 0451</p>		
<p>Housing surface mounting</p> 	<p>09 40 048 0951</p>		
<p>Han HC Modular Housing bulkhead mounting</p> 	<p>09 40 048 0311</p>		
<p>Housing bulkhead mounting for 4 standard inserts size 16 B</p> 	<p>09 40 048 0331</p>		

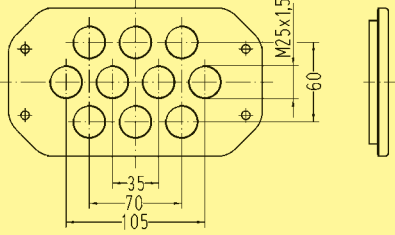
Identification	Part No.	Drawing	Dimensions in mm
<p>Cover* without cable entry</p> 	09 40 048 9801		
<p>Cover* 4 x M40 for male inserts</p> 	19 40 048 9801		
<p>Cover* 4 x M40 for female inserts</p> 	19 40 048 9901		
<p>Cover* 6 x M25 6 x M32</p> 	19 40 048 9820 19 40 048 9822		
<p>Cover* 5 x M32</p> 	19 40 048 9812		
<p>Cover* 10 x M25</p> 	19 40 048 9860		

Han HC
Modular

* Included in delivery range: 4 distance pieces
4 screws M6
4 washers

Stock items in bold type

Identification	Part No.		Depiction
	Male (M)	Female (F)	
<p>Frame for 4 standard inserts size 16 B</p> <p>Suitable for hoods and surface mounted housings only</p>	09 40 048 9912	09 40 048 9912	
<p>Frame for 4 x HC 350 contacts + 2 x Han® Q 5/0</p>	09 40 048 9810	09 40 048 9910	
<p>Frame for 4 x HC 650 contacts + 2 x Han® Q 5/0</p>	09 40 048 9811	09 40 048 9911	
<p>Han HC Modular</p> <p>Frame for 6 x HC 350 contacts</p>	09 40 048 9806	09 40 048 9906	
<p>Frame for 4 x HC 350 contacts + PE</p>	09 40 048 9809	09 40 048 9909	
<p>Frame for 10 x HC 350 contacts</p>	09 40 048 9860	09 40 048 9960	